

HAS457-2®

Helicopter Antenna System 457 kHz (Helicopter Based Search for Avalanche Victims)

User Manual Technical Data



Author : Marcel Würgler
Version : 01.00
Created : June 09, 2018 10:10 AM
Modified : August 29, 2018 17:15 PM
File Name : HAS457-2 User Manual.docx

Copyright© 2018, Girsberger Elektronik AG. All rights reserved. This is a proprietary document of Girsberger Elektronik AG. Its contents must not be disclosed, forwarded or made known in any other way to third parties.

Contents

1. Introduction	4
2. Description.....	4
3. Development History	4
3.1 The Current System	4
3.2 The New System	4
4. Main Features, Advantages.....	5
4.1 Previous and Maintained Features.....	5
4.2 New Features and Advantages	5
5. System Components	6
5.1 Receiver.....	6
5.1.1 Block Diagram	6
5.1.2 Controls and Indicators on the Front Side.....	7
5.1.3 Controls and Connectors on the Rear Side.....	8
5.1.4 Power Supply, Battery Compartment	9
5.2 Antenna and Range.....	9
5.3 The Antenna Cable.....	9
5.4 The Intercom Cable	10
5.5 The Earphone.....	10
5.6 The Transportation Bag.....	10
6. Integration Into a Helicopter	10
6.1 Interference and Antenna Position	10
6.2 Audio Signal.....	11
6.2.1 Intercom MIC Input	11
6.2.2 Intercom AUX Input	11
6.2.3 Earphone Connector	11
7. Helicopter Crew	12
7.1 Prerequisites, Basics, Formation, Training.....	12
8. Search	12
8.1 System Preparation	12
8.2 Recommendations for Performing a Search	13
8.3 Search Phases	13
8.3.1 Signal Search	13
8.3.2 Coarse Search.....	13
8.3.3 Marking.....	13
8.3.4 Fine Search	13
9. Strategy	14
10. Additional Recommended Equipment	14
11. SOP (Standard Operating Procedure)	14
12. Compatibility.....	14
13. Technical Data	15
13.1 Receiver.....	15
13.2 Antenna	15
13.3 Antenna Cable	15
13.4 Intercom Cable	15
13.5 Earphones	16
13.6 Carrying Bag.....	16
13.7 System.....	16

14. Functional Test 17
 14.1 Prerequisites 17
 14.2 Procedure 17
15. Maintenance 18
16. Warranty 18
17. Information 18

Document Versions

00.00	June 17, 2018	first draft, unofficial prerelease
00.01	July 6, 2018	rework
00.02	July 11, 2018	rework
01.00	August 29, 2018	rework, official release
01.01		
01.02		

Please read the following warnings before first use:



- The system is only intended for use by professionals.
- Read and follow all instructions in this manual.
- The system must be installed by a qualified technician as per this manual.
- Only use batteries of the specified type.
- Do not modify any of the system devices.
- Do not modify any part of the antenna cable and of the intercom cable.
- If any devices or cables are damaged, return them to the manufacturer for repair.
- Do not open the devices. Opening any device will void all warranties.
- A complete functional check must be done by the manufacturer only.

Recycling:



Do not dispose of the devices as household waste. You are obliged to dispose of them at a center for recycling electronic devices.



1. Introduction

This document describes the helicopter based system for searching for avalanche victims HAS457-2 of Girsberger Elektronik AG - Mountain Rescue Technology.

2. Description

The professional system HAS457-2 provides a very fast search by helicopter for persons who have been buried in an avalanche, provided that the persons are carrying an avalanche transceiver.

The primary use is with large avalanches, in case of danger of secondary avalanches or other objective dangers. The system is also very advantageous for searching for missed persons on any kind of terrain such as avalanches, crevasses, forests, gorges or other inaccessible areas.

The system features an omnidirectional antenna that will receive signals from transceivers from all directions with equal sensitivity.

For performing a search, the antenna is suspended a few meters below the helicopter in order to avoid any interference from the electromagnetic signals emanated by the helicopter.

For searching a signal, the helicopter flies over the search area according to procedures as specified. The ensuing coarse search uses the classical method of bracketing on two orthogonal axes. Once a transceiver has been located, the spot is marked with a flag (heavy object with marker band attached) and a rescuer is lowered by means of the winch or exits to ground for performing a fine search.

The HAS457-2 is only used temporarily, there is no need for permanent installation or modifications to the helicopter. The system must be stored in the helicopter during the winter season. The complete system, ready for use, is stored in a special bag and can be deployed within a very short time.

3. Development History

3.1 The Current System

The first helicopter based system for the search of avalanche victims that was using an omnidirectional antenna was developed and marketed by Girsberger Elektronik AG in the year 2000. It was first designated the VS2000 Pro and later on renamed to HAS457.

The system as proved very effective with many rescue organizations all over the world and has saved many lives.

3.2 The New System

In the year 2015 we decided to do a re-development of the entire system.

The focus was put on increasing the search efficiency by means of an optical distance and direction information as well as on extending the range.

Various studies, hardware and software developments and extensive field tests showed that the development effort would become exorbitant, that the system would require certification due to the installation of fixed hardware in the helicopter, that an additional device (tablet computer) would be required for control and display, that the range would be reduced, that the maintenance of the software would require a considerable effort and that the final system cost would be very high.

Based on these insights, we decided in 2017 to not change to a digital system but keep the analog system.

The new receiver provides an optical signal strength indicator that will support the search and will also help in identifying interferers and performing a functional test. Over all, the system has become more compact, provides an increased range and various new useful details that will be described in the following (4.2).

4. Main Features, Advantages

4.1 Previous and Maintained Features

- Increased area search speed due to helicopter
- Reduction of search time
- Better safety for the rescue squad
- Reduction of the cost of rescue
- Higher chances of survival for buried persons
- Large width of search strip
- Classical orthogonal search procedure (bracketing)
- Active omnidirectional antenna
- Battery operation
- Galvanically separated and adjustable connection to the intercom system
- Compatible with all avalanche transceivers (EN 300718)
- Professional and robust construction
- Professional connectors
- Easy to use, immediately deployable
- Developed and manufactured in Switzerland
- Successful use all over the world

4.2 New Features and Advantages

- Robust aluminum case for the receiver providing shock protection
- Optical (20 LED bar) received signal strength indicator
- Three level sensitivity adjustment
- Increased range (+ 20%)
- Integrated 3 level intercom impedance adjustment with level control
- Additional earphone connectors with level control
- Improved battery monitoring
- Longer operating time
- Smaller overall dimensions
- Screw-locked case
- Safety through panic hook on the antenna cable
- Antenna cable protected by Polypropylene tubular webbing
- Robust transportation bag providing overall shock protection and reinforced bottom
- Compatible with the current system

5. System Components

5.1 Receiver



The receiver is housed in a robust Aluminum profile case that is protected by a shock absorber. The front side provides the controls and the display. The rear side provides further controls as well as all connectors.

5.1.1 Block Diagram

The block diagram provides a simplified version of the signal flow, the main components and the connection points.

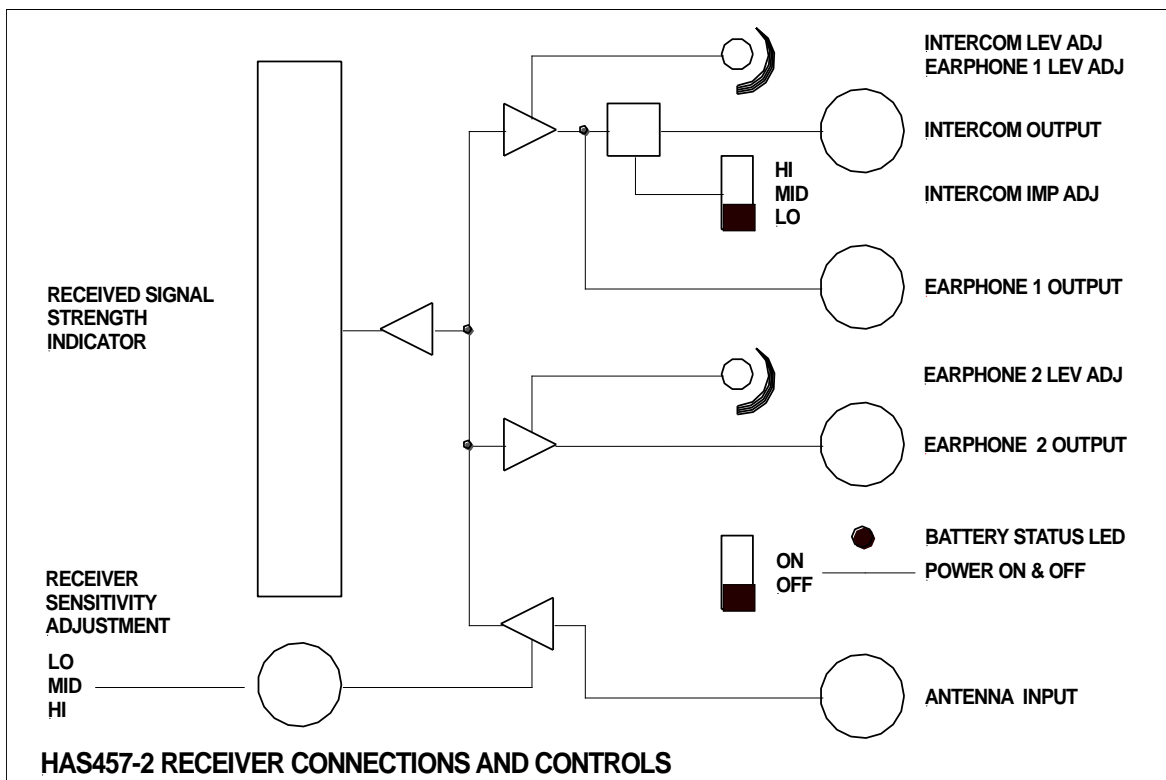

5.1.2 Controls and Indicators on the Front Side

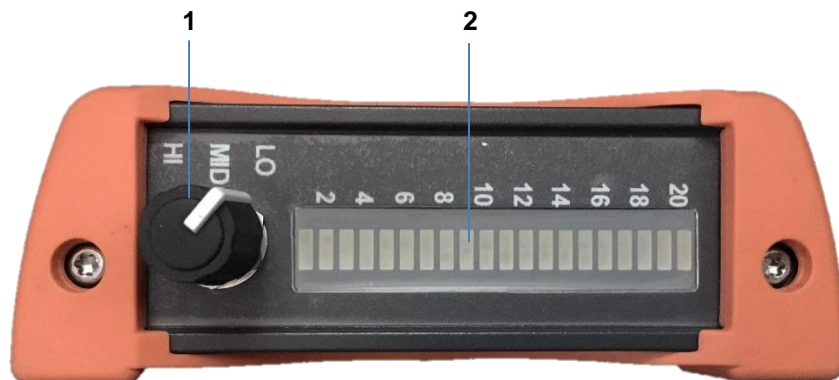

5.1.2.1 Receiver Sensitivity Adjustment

The three position rotary switch is for setting the receiver sensitivity.

- Position HI: 90 m to 30 m
At distances below 30 meters, all 20 LEDs are on, the receiver has become saturated, and the sensitivity must be changed to MID.
- Position MID: 30 m to 15 m
At distances below 15 meters, all 20 LEDs are on, the receiver has become saturated, and the sensitivity must be changed to LO.
- Position LO: 15 m to 5 m
At distances below 5 meters, all 20 LEDs are on, the receiver has become saturated, and localization at closer distances is not possible.

5.1.2.2 Received Signal Strength Indicator

The 20 LED bar signal strength indicator is for monitoring the received signal. An intermittent indication, about once per second (pulse period of a transmitting transceiver), indicates a signal from a transceiver. If the LEDs are on continuously, this indicates some interference on the 457 kHz frequency. Possible interference can thus easily be recognized. The display is also helpful for system integration and for functional testing.

5.1.3 Controls and Connectors on the Rear Side

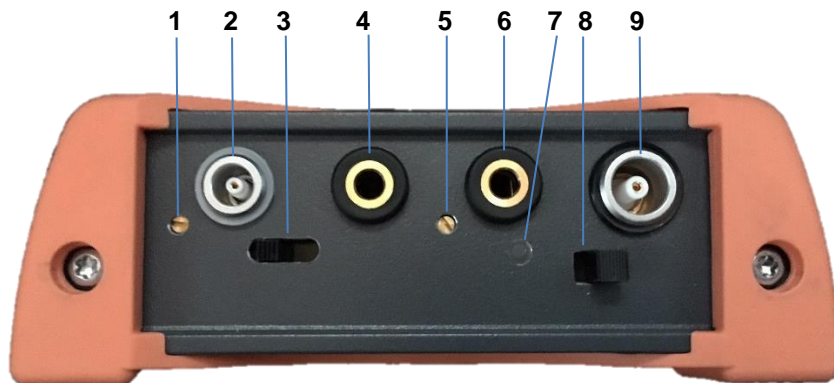

5.1.3.1 Intercom Signal & Earphone 1 Level Adjustment

This control is for setting the audio signal level for the intercom connector (2) and for the earphone connector (4).

It is a 25 turns control with sliding clutch at both ends. Turning the screw clockwise increases the signal level.

5.1.3.2 Intercom (ICS) Connector (Output)

This connector provides the audio signal for connecting to the helicopter intercom system (LEMO socket 00 series).

The audio signal is galvanically separated and may be adjusted to the helicopter intercom system by means of the sliding switch (3) and the level control (1).

5.1.3.3 Intercom (ICS) Impedance Matching Sliding Switch

This three position sliding switch serves for optimum adaptation of the audio signal to the input of the helicopter intercom system.

Position HI: 12 mV_{rms} to 1700 mV_{rms} @ 200 Ohms / 20 mV_{rms} to 3200 mV_{rms} @ 1000 Ohms

Position MID: 2 mV_{rms} to 300 mV_{rms} @ 200 Ohms

Position LO: 0.1 mV_{rms} to 15 mV_{rms} @ 10 Ohms

5.1.3.4 Earphone 1 Connector

This 3.5 mm socket is used for connecting a mono or stereo earphone. The level may be set by means of the control (1). The audio signal is parallel to the intercom connector (2).

The minimum impedance of the earphone is 8 Ohms or 16 Ohms per side.

5.1.3.5 Earphone 2 Level Adjustment

This control sets the signal level for the connector (4). It is a 25 turns control with sliding clutch at both ends. Turning the screw clockwise increases the signal level.

5.1.3.6 Earphone 2 Connector

This 3.5 mm socket is used for connecting a mono or stereo earphone. The level may be set by means of the control (5). The minimum impedance of the earphone is 8 Ohms or 16 Ohms per side.

5.1.3.7 Battery Status LED

This LED indicates the remaining battery capacity while the device is on.

Green LED: > 60 hours
 Orange LED: > 6 hours
 Red LED: replace batteries immediately!

5.1.3.8 Power ON / OFF Slide Switch

This switch is for turning on the receiver.

5.1.3.9 Antenna Connector

This is the connector for the active antenna (LEMO socket 0S series).

5.1.4 Power Supply, Battery Compartment

The power is supplied by 3 1.5 Volt standard alkaline cells of type IEC-LR06 (AA). The battery compartment is closed by means of two Philips type screws. Do not use any other battery technologies than alkaline. If not so, the battery status indication will not be reliable. We recommend to use professional alkaline batteries only.

5.2 Antenna and Range

The system comes with an omnidirectional antenna that provides equal sensitivity to signals from all directions.

The range is 90 meters in case of optimum coupling position with a transceiver.

The following search strip widths are achievable independently of the coupling position:

Antenna elevation above ground	Search strip width
30 m	60 m
20 m	80 m
10 m	100 m

These ranges can only be achieved if the antenna is outside the area of interference generated by the helicopter. They may also be affected by interference from other nearby installations that use electronic equipment.

While doing a search, do not keep any metal objects near the antenna. These would be damping the antenna and reduce the range.

The antenna is linked to the bag with a Velcro connection that should never be detached. It is very sensitive to mechanical stress and shock and should never be thrown or fall.

5.3 The Antenna Cable

The antenna cable comes with professional connectors. It is protected by a Polypropylene tubular webbing. It is hooked to the helicopter at the upper end by means of a panic hook. The hook is preferably hooked above the helicopter door to a point that is intended for connecting a load.

If the necessity arises where the antenna as well as the antenna cable must be disconnected as fast as possible, the panic hook can easily be opened even under load.

5.4 The Intercom Cable

The intercom cable comes with professional NATO TP-120 Nexus to LEMO connectors. Customer specific configurations with different length or connectors such as TP-101, ASTL10, PJ-055B, PJ-068, XLR Connector, Stereo Phone Jack 3.5 mm (Auxiliary Entertainment Music Input), MPC Connector (Multi-Purpose Connector) may be provided.

5.5 The Earphone

For direct listening to the audio signal, two extremely lightweight mono earphone buds are provided (Sennheiser EP 01-R140). These may be used when connecting to the helicopter intercom system is not permitted or not possible otherwise. They are preferably worn inside an ear cushion or helmet. This allows for simultaneous listening to the intercom. Exchangeable ear cushions meet the comfort and hygiene requirements.

5.6 The Transportation Bag

The transportation bag stores all the components for a ready-to-use system. The cover opens by means of a zipper. The bag is made of a very robust material and provides complete shock protection. For the bottom part, a reinforced material is used.

6. Integration Into a Helicopter

In order to achieve the best system performance (for range see 5.2), the following points are very important and a mandatory prerequisite for a successful and efficient localization of buried victims.

Most rescue operations are turbulent, and there is no time for optimizing the settings on the intercom panel.

6.1 Interference and Antenna Position

The engine, the ignition as well as the on board electronics of the helicopter do create interference that may affect the receiver performance of the HAS457-2 system.

The antenna must therefore be kept outside the range of interference caused by these sources. Experience has indicated that for most helicopters, a distance of 3.5 to 5 meters as given by the antenna cable is sufficient. If not so, longer antenna cables can be provided. But, for reasons of safety, the antenna cable must not be longer than the distance from the point of attachment to the tail rotor.

The antenna cable should be attached above the door. The antenna is then lowered in flight before the start of the actual search.

Further interference may be caused by e.g. transponders, strobe lights, and winches. Those devices are not required for a search by helicopter and must be switched off.

The receiver should only be turned on after the antenna has been connected and lowered. This avoids any overlap of the wanted audio signal with interference.

We recommend doing a test flight over a suitable (interference-free) area. For that purpose, attach and connect the antenna cable to the hook and to the receiver. Then lower the antenna. Set the receiver to maximum sensitivity. At most 2 or 3 LEDs should be on. If more LEDs are on, there are some sources of interference that must be located and then eliminated (switched off).

6.2 Audio Signal

In order to listen to the audio signal that is available at the intercom socket, (5.1.3.2), there are three options:

6.2.1 Intercom MIC Input

Audio signal input to the intercom system via a VOX controlled MIC input (headset input).

This type of input is not recommended but for very experienced users or for users of the previous system.

There are many different intercom systems. Some provide many settings, others don't even provide the absolutely necessary settings. Even for experienced users, it is very difficult to find the best settings for receiving weak signals during the integration and the use in emergency situations. When a VOX controlled MIC input is used, the audio signal level may have to be set too high, which may reduce the achievable range considerably.

The intercom input must be set to HOT-MIC. All other active intercom system inputs must be set to KEY, so they will not input any environmental noise. The level of the intercom input should be set to about 2/3.

Since intercom systems do have various input specifications, the receiver provides for impedance and level adjustments that are described under 5.1.3.3.

6.2.2 Intercom AUX Input

Audio signal input via an input with no VOX control (Music, AUX or MPC).

This is the preferred way for audio signal input since it is much easier to handle. The audio signal can be easily added or mixed to the intercom system.

Since intercom systems do have various input specifications, the receiver provides for impedance and level adjustments that are described under 5.1.3.3.

For large organizations with multiple helicopter types, a further advantage of this method is the interchangeability of the systems.

Even if such an input is not available on a particular system, it can usually easily be refurbished at little cost.

6.2.3 Earphone Connector

Direct connection of an earphone that is installed under the ear cushion of a headset or helmet.

This is the most preferred method for the following reasons:

- No need to connect to the intercom system (6.2.1)
- No need to change settings on the intercom panel (6.2.1)
- When connecting to the intercom system is not permitted/possible for reasons of safety
- The method is immediately ready for use
- The method permits to listen to both the intercom and to the search signal simultaneously (6.2.1 and 6.2.2)

7. Helicopter Crew

- Pilot
- Rescue specialist (winch operator or other)
- Medical doctor or other specialized persons

A search requires at least the pilot and one additional person. With large events, additional helpers may be of advantage.

7.1 Prerequisites, Basics, Formation, Training

The following prerequisites are a must:

- The HAS457-2 has been integrated into the helicopter (6)
- The HAS457-2 and the intercom setup are prepared before starting a rescue (8.1)
- A basic flight training
- Formation for the use of the HAS457-2
- Knowledge of terrestrial avalanche search procedures
- Repeated training of the search, in flight as well as on the ground

8. Search

The HAS457-2 system provides a very fast signal and coarse search for locating persons who have been buried in an avalanche and who are carrying an avalanche transceiver.

8.1 System Preparation

Before starting a search, the system and the intercom setup must be prepared. Also, the system integration (6) is an absolute prerequisite.

The preparation is done on the grounded helicopter in the following sequence:

1. Open the transportation bag, remove the receiver, the antenna cable and the intercom cable.
2. Roll out the antenna cable and attach above the door by means of the panic hook.
3. Connect the antenna cable to the receiver antenna socket (5.1.3.9).
4. Connect the intercom cable to the receiver intercom socket (5.1.3.2).
5. Connect the intercom cable to the appropriate intercom panel (usually the rear panel for the medical person).
6. Install the receiver near the pilot or a crew member.
7. Disconnect all unused headsets / helmets from the intercom system.
8. Connect all used headsets / helmets.
9. Turn on and set up the intercom system.
10. Place the antenna about 2 meters to the side of the helicopter.
11. Turn on the receiver and set it to (LO) sensitivity.
12. For a system check, turn on an avalanche transceiver in transmit mode and place it in axis with the antenna at a distance of about 12 meters.
13. The signal must be clearly audible and free of interference. The display must show a periodic indication (about 1 per second) up to the center of the LED bar.
14. If everything works OK, switch off the receiver and set it to maximum sensitivity (HI) for the search.

15. Switch off the avalanche transceiver and store it in the helicopter together with the antenna.
16. The system is now ready for use.

In case of using method (6.2.3) for integration (6), i.e. there is no intercom connection, points 4 and 5 are replaced by connecting the headphones for the pilot and for the additional crew member.

8.2 Recommendations for Performing a Search

- Use a search strip width of 20 meters.
- Use horizontal search strips.
- Make the search strips to the side and at the bottom of the avalanche overlap.
- In bad visibility caused by snowfall or wind, increase the overlap.
- The preferred search speed is 5 km/h.
- The antenna elevation above ground should be 5 to 15 meters. The elevation depends on the terrain and on the snow characteristics. If possible, the elevation may be reduced down to 5 meters when approaching a buried person.
- At a distance of 5 meters, the receiver starts saturating. Localization below this distance is therefore not possible.
- The crew member adjusts the receiver sensitivity (5.1.2.1) based on instructions by the pilot, or the pilot adjusts the receiver sensitivity himself.
- The nose of the helicopter should always face the slope.
- Use a mirror for the pilot for checking the antenna position at close distances.
- In case of multiple burials with closely located victims, the coarse and fine searches are done on the ground by rescuers.
- Instructions from the local site manager are to be followed.

8.3 Search Phases

The search phases as per the recommendation (8.2) are to be applied.

8.3.1 Signal Search

The signal search starts with horizontal search strips and ends with the reception of a first signal.

8.3.2 Coarse Search

The coarse search begins with the reception of a first signal and ends at a distance of 5 meters to the buried subject. Location is by means of the classical bracketing method. At this distance, the receiver is saturated, and more precise location is not possible.

8.3.3 Marking

After location, the spot is flagged by some means, and a rescuer is lowered by the winch or put on the ground.

8.3.4 Fine Search

The fine search is done on the ground by a rescuer.
In difficult conditions (secondary avalanches), the fine search may be done on a long line.
This final phase of the search cannot be done by means of the helicopter. Also, too much time would be lost.

9. Strategy

1. Before performing a search, the area must be flown over in order to collect additional information: Size of avalanche, possibility of secondary avalanches, possible obstacles such as cables, visual search for body parts or equipment. During this flight, the antenna remains inside the Helicopter.
2. Return to the starting point, preferably at the bottom of the debris.
3. Open the side door. The operator must be belayed as per regulations.
4. Put out the antenna while hovering, close the door if possible.
5. Turn on the receiver at maximum sensitivity (HI).
6. Start the signal search as per (8.3 & 8.3.1).
7. When receiving a signal, proceed to the coarse search (8.3.2) and use classic bracketing. The coarse search ends when the distance to the buried person is below 5 meters.
8. Mark the location of the buried subject. (8.3.3).
If possible, record the coordinates.
9. Put a crew member on the ground or descend by winch. Start the fine search (8.3.4). Under difficult conditions (danger of secondary avalanches), the fine search may be done on a long line.
10. Dig out the buried person immediately, using advanced shoveling techniques. Free the airways and start first aid procedures. Do not forget to check if there was a breathing pocket. If the mouth, nose and throat are free of snow, you may assume a breathing pocket. Record the actual time.
11. Turn off the buried person's transceiver immediately.
12. Continue the search by helicopter on the remaining avalanche area.

10. Additional Recommended Equipment

- 3 to 5 flags (heavy object with marker band attached)
- 3 avalanche transceivers
- 3 avalanche shovels
- 3 avalanche probes, length > 3 m
- 3 spare batteries

11. SOP (Standard Operating Procedure)

We recommend that you prepare a SOP document for the entire procedure.

12. Compatibility

The HAS457-2 is compatible to all avalanche transceivers that adhere to the specifications as per the standard EN300718 and operate at a frequency of 457 kHz.

13. Technical Data

13.1 Receiver

Type:	HAS457-2 Receiver
Frequency range:	457.0 kHz +/- 100 Hz
Power supply:	3 Standard cells Type IEC – LR06 alkaline 1,5V (AA)
Current consumption (no signal):	22 mA
Maximum current consumption:	160 mA
Sensitivity:	10 nA/m
Intercom output:	galvanically separated, adjustable level and impedance
	Position HI 20 mV _{rms} to 3200 mV _{rms} @ 1000 Ohms
	Position HI 12 mV _{rms} to 1700 mV _{rms} @ 200 Ohms
	Position MID 2 mV _{rms} to 300 mV _{rms} @ 200 Ohms
	Position LO 0.1 mV _{rms} to 15 mV _{rms} @ 10 Ohms
Intercom connector:	LEMO socket 00 series
Earphone 1 impedance:	Min. 8 Ohms or min. 16 Ohms / side
Earphone 1 connector:	3,5 mm Mono / Stereo jack
Earphone 2 impedance:	Min. 8 Ohms or min. 16 Ohms / side
Earphone 2 connector:	3,5 mm Mono / Stereo jack
Operating temperature range:	- 20° C to + 40° C
Case material:	Aluminum
Dimensions:	150 x 103 x 37 mm
Weight:	620 g (incl. batteries)
Compatibility:	EN 300718

13.2 Antenna

Type:	HAS457-2 Antenna
Frequency range:	457.0 kHz +/- 100 Hz
Directivity:	Omnidirectional 360°
Power supply:	By receiver
Operating temperature range:	- 25° C to + 40° C
Case material:	Fiber-reinforced Polycarbonate
Dimensions:	200 x 200 x 180 mm
Weight:	2490 g
Protection class:	IP 68

13.3 Antenna Cable

Cable type:	H & S / G-03212-01
Connectors:	H & S / TNC, LEMO 0S Series
Tubular webbing material:	Polypropylene
Fixture:	Panic hook
Mechanical / electrical length:	5,5 m / 8,5 m
Weight:	960 g

13.4 Intercom Cable

Cable type:	GE-PED 1378
Connectors:	Nexus TP-120 (NATO), LEMO 00 Series
Length:	2,0 m
Weight:	80 g

13.5 Earphones

Type:	Sennheiser EP 01-R140
Connector:	Mono 3,5 mm jack
Cable length:	1,4 m
Weight:	10 g

13.6 Carrying Bag

Dimensions:	220 x 220 x 280 mm
Weight:	440 g

13.7 System

Total weight:	4600 g
---------------	--------

14. Functional Test

A simple functional test may be done by the user as described under (14.2). A full functional test can only be done by the manufacturer.

14.1 Prerequisites

The functional test must be performed in an interference-free environment. Make sure there are no electrical conductors (cables, pipes etc.) underground. Keep a minimum distance of 200 meters to technical buildings and installations.

14.2 Procedure

1. Place an avalanche transceiver with new batteries at a distance of 50 meters. Align the main antenna with the main axis of the HAS457-2 antenna.
2. Connect the HAS457-2 antenna to the receiver.
3. Turn on the receiver (use new batteries) and set it to maximum sensitivity.
4. You should now receive the signal from the avalanche transceiver and get an indication on the LED bar display.
A periodic (about once per second) indication up to the center of the bar indicates proper functioning of the system.
A permanent indication is caused by interference. Look for a test site with no interference. In addition, you may check the audio signal by means of the earphone.
5. Rotate the antenna about all 3 axes. The bar length should always be 9 to 10 LEDs.
6. Turn off the avalanche transceiver and the HAS457-2 receiver.
7. If you do not get an indication nor an audible signal, the system must be returned to the manufacturer for a full functional test.

15. Maintenance

- The entire system should be returned to the manufacturer (Girsberger Elektronik AG) every 3 years for a detailed test on all specified items.
- The receiver batteries are to be replaced every year.
Hint: Remove the batteries at the end of the season in order to avoid damage to the electronics.

16. Warranty

Limited two year warranty

Girsberger Elektronik AG provides a two year warranty, starting from the date of purchase as per the purchase papers.

Warranty conditions

The system is installed and operated as described in this manual.

All parts that exhibit material or production faults will be replaced.

Damage by improper use or normal wear is not covered.

All adaptations, modifications or repairs have been done by Girsberger Elektronik AG.

The warranty is void if any device has been opened by the owner or by some third party.

The warranty is void if any device has been used in conjunction with other equipment or replacement parts that have not been approved by the manufacturer.

17. Information

This document is protected by copyrights.

This document may not be copied or disclosed to other parties without the explicit written consent of Girsberger Elektronik AG.

Technical data may change without prior notice at any time.